

# Little GIANT<sup>®</sup> Pump Company

Big John  
Submersible  
Sump Pumps

## 8 SERIES



### Features

- Cast bronze or cast iron pump housing with protective epoxy coating for corrosion resistance
- Oil-filled motor housing for lifetime lubrication and rapid heat dissipation
- 4/10 HP Shaded Pole Motor
- Stainless steel fasteners
- Mechanical seal (stainless steel spring, nitrile parts, carbon and ceramic faces) to assure maximum protection against pump failure
- Bearings: Upper and lower sintered sleeve bearings for extended motor life
- Thermal overload protection
- Manual and automatic models
- Automatic operation with pressure switch activates pump when water level is between 7" and 10". Pump shuts off when water level falls to between 1" and 4" (Pressure switch is non-adjustable)

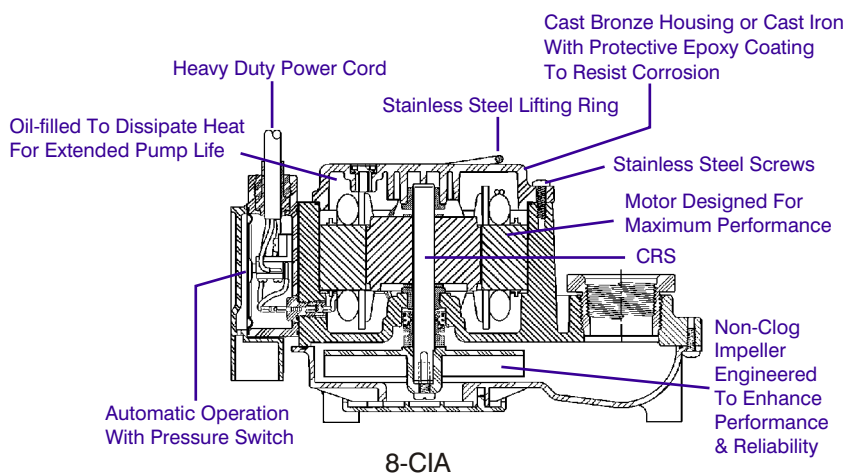

For residential and light commercial use, the Model 8 Series sump pumps provide efficient and reliable service. For extended or continuous use in moving large volumes of water, these pumps feature a 1-1/2" discharge with a maximum head of 22.9', a polycarbonate cover and a polypropylene volute/base. A choice of manual or automatic versions provides user with the right pump for their needs.

# Little Giant Pump Co.

## 8 SERIES SUMP PUMPS

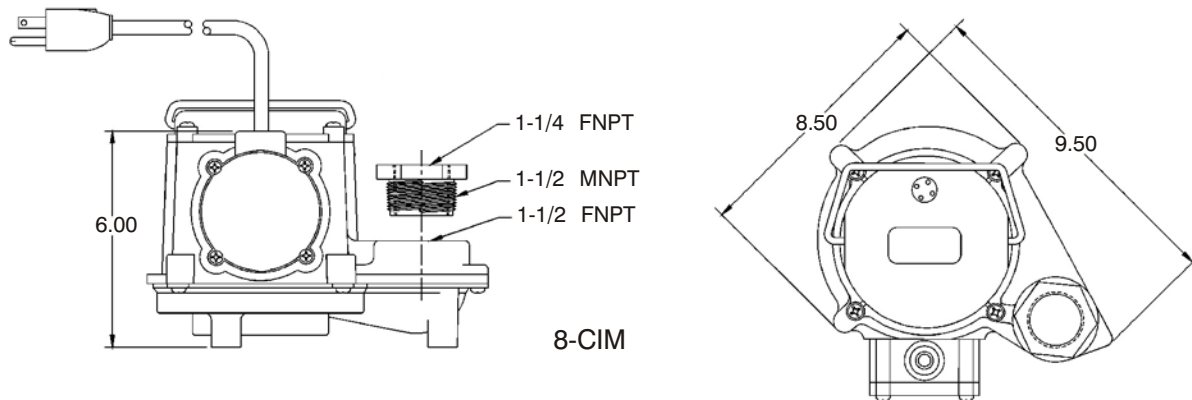
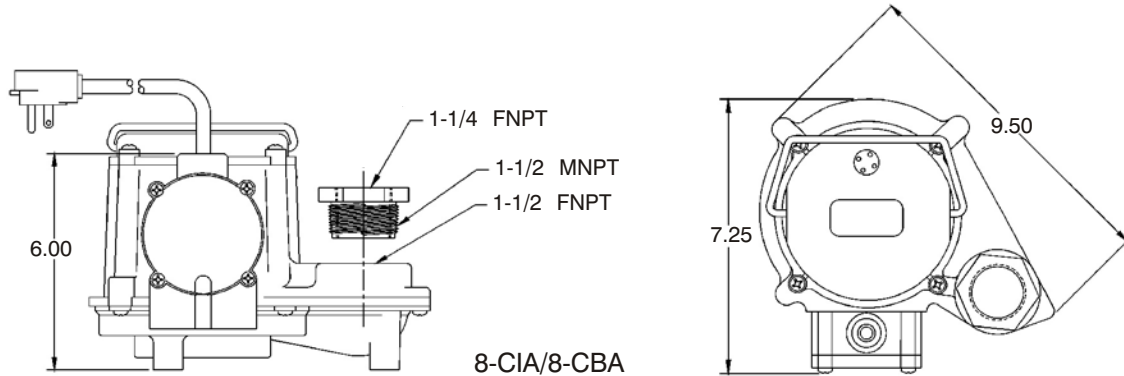

### Specifications

MODEL NO.	ITEM NO.	LISTING	HP	VOLTS	RUNNING		FLOW (GPM@HEAD)			SHUTOFF HEAD (FT.)	PWR. CRD. (FT.)	WEIGHT (LBS.)	DIMENSIONS (H x L x W) (IN.)	
					AMPS	WATTS	5	10	15					
8-CIM	508057	UL/CSA	4/10	115	10	830	54	42	26	22.9	9.9	10	18.80	6.00 x 9.50 x 8.50
8-CIM	508058	UL/CSA	4/10	115	10	830	54	42	26	22.9	9.9	25	19.80	6.00 x 9.50 x 8.50
8-CBM	508257	UL/CSA	4/10	115	10	830	54	42	26	22.9	9.9	10	21.00	6.00 x 9.50 x 8.50
8-CIA	508157	UL/CSA	4/10	115	10	830	54	42	26	22.9	9.9	10	19.00	6.00 x 9.50 x 8.50
8-CIA	508158	UL/CSA	4/10	115	10	830	54	42	26	22.9	9.9	25	20.30	6.00 x 9.50 x 8.50
8-CBA	508357	UL/CSA	4/10	115	10	830	54	42	26	22.9	9.9	10	21.30	6.00 x 9.50 x 8.50

Continuous Duty Rated — "Little Giant Wastewater pumps are rated continuous duty as long as they are run within the published ratings for these pumps."  
 CIM/CBM — Manual      CIA/CBA — Automatic      All models are 60Hz.

### Construction

Motor Housing	Epoxy-coated Cast Iron (CI) or Cast Bronze (CBM and CBA Models)
Impeller Material	Polypropylene
Impeller Type	Non-Clog
Volute	Polypropylene
Power Cord	18-3, SJTW
Mechanical Shaft Seal	Nitrile with Carbon & Ceramic Faces
Fasteners	Stainless Steel
Shaft	CRS
Bearings	Upper and lower: Sintered, Iron, Flanged Sleeve

