

1 & 3 METER TOWER

CAT-1M-203R – RIGHT MOUNT – CAT-3M-203R
CAT-1M-203L – LEFT MOUNT – CAT-3M-203L
CAT-1M-203D – DUAL MOUNT – CAT-3M-203D
CAT-1M-203H – HEEL MOUNT – CAT-3M-203H

WARNING

CAUTION: DIVING BOARD AND TOWER COMBINATIONS MUST MEET THE ANSI/NSPI-1 1991 STANDARD FOR PUBLIC SWIMMING POOLS. COMPLY WITH LOCAL GOVERNMENT REGULATIONS IF THEY EXCEED THE ANSI/NSPI-1 STANDARD.

All diving boards and related equipment are manufactured for swimming pools ONLY. The S R Smith 1 & 3 Meter Towers are designed to be easily transported and installed. Follow all instructions carefully and inspect closely to assure proper and safe installation.

PROPER INSTALLATION CANNOT BE OVERSTRESSED,
AS AN IMPROPER INSTALLATION VOIDS S.R. SMITH'S WARRANTY.

IMPORTANT
ASSEMBLY AND INSTALLATION INSTRUCTIONS
– PLEASE READ CAREFULLY –

S.R. Smith, LLC

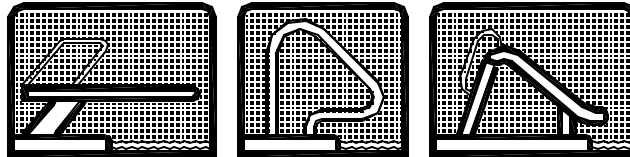

WORLD'S LARGEST MANUFACTURER OF
DIVING BOARDS, SLIDES &
STAINLESS STEEL
RAIL PRODUCTS

WESTERN SALES AND MANUFACTURING PLANT
CORPORATE HEADQUARTERS

P.O. Box 400 • 1017 S.W. Berg Parkway
Canby, Oregon 97013
Phone (503) 266-2231 • FAX (503) 266-4334



EASTERN MANUFACTURING PLANT
105 Challenger Drive
Portland, Tennessee 37148
Phone (615) 325-0770 • FAX (615) 325-0775



1 & 3 METER TOWERS

Chart 1 RULE SHEET

Refer to Fig. 1 & 2

From ANSI/NSPI-1 1991 STANDARD FOR PUBLIC SWIMMING POOLS

| Model | Board A | Pool Type | Distance For Setting Front Bolt of Jig From Water's Edge B | Fulcrum Setting $c \pm 6"$ | Minimum Overhang $L_1 \pm 3"$ | Max. Height of Board Above Water D |
|---------|------------|-----------|---|----------------------------------|-------------------------------------|---|
| 1 METER | 14' | VIII | 36-5/16" | 74" | 4'-0" | 39-3/8" |
| 1 METER | 16' | VIII | 60-5/16" | 86" | 4'-0" | 118-1/8" |
| 1 METER | 14' | IX | 12-5/16" | 74" | 6'-0" | 39-3/8" |
| 1 METER | 16' | IX | 36-5/16" | 86" | 6'-0" | 118-1/8" |
| 3 METER | 14' | IX | 33-1/4" | 74" | 6'-0" | 39-3/8" |
| 3 METER | 16' | IX | 57-1/4" | 86" | 6'-0" | 118-1/8" |

THE FULCRUM SETTING DIMENSION "C" IS MEASURED FROM CENTER OF MOUNTING HOLES TOWARD TOE END OF BOARD

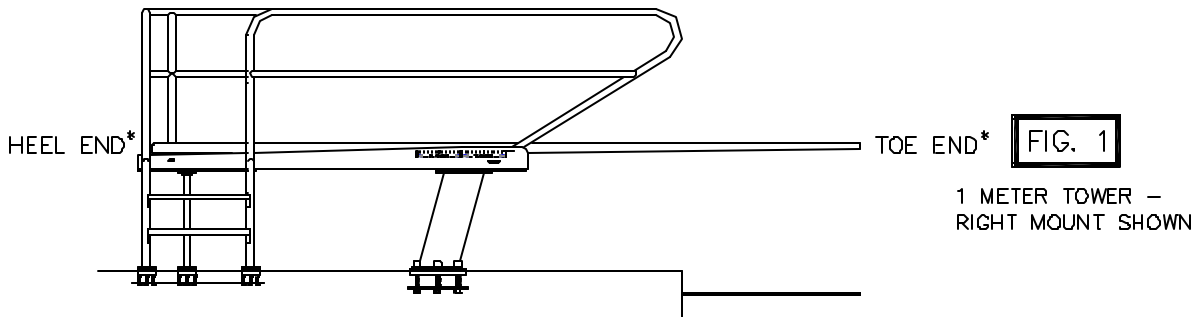

1 METER TOWER -
RIGHT MOUNT SHOWN

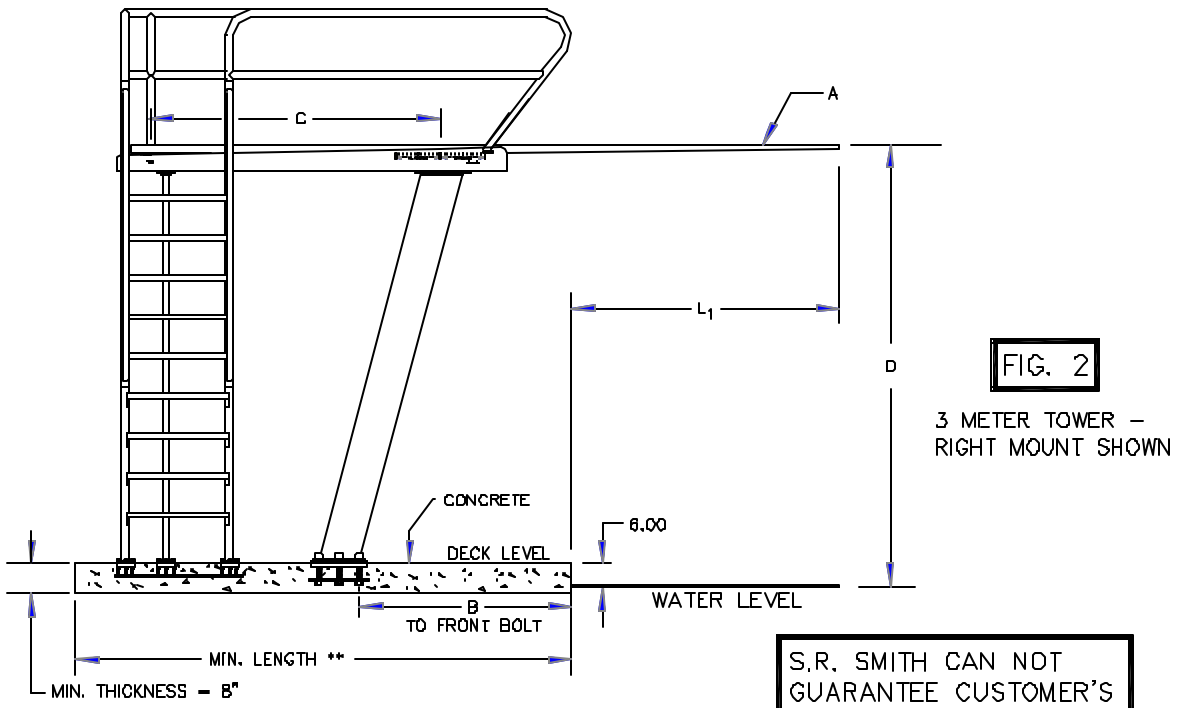

3 METER TOWER -
RIGHT MOUNT SHOWN

S.R. SMITH CAN NOT
GUARANTEE CUSTOMER'S
CONCRETE OR THICKNESS

RECOMMEND compressive strength of concrete to be 3500 psi or greater

* ANSI/NSPI refers to Heel as Butt and Toe as Tip ends of board

** MIN. LENGTH: Add 15" to the Y3 dimension (Right, Left or Dual Mount Tower) or the Y4 dimension (Heel Mount Tower) found in Fig. 3 (page 3) and Chart 2 (page 4).

MIN WIDTH OF CONCRETE 1 Meter Tower is 80 inches and 3 Meter Tower is 121 inches.

INSTALLATION INSTRUCTIONS FOR METER TOWER

CAUTION: DIVING BOARD AND TOWER COMBINATIONS MUST MEET THE ANSI/NSPI-1 STANDARD FOUND ON PAGES 13 THROUGH 16 OF THIS BOOKLET. COMPLY WITH THE LOCAL GOVERNMENT REGULATIONS IF THEY EXCEED THE ANSI/NSPI-1 STANDARD.

PLACEMENT OF JIGS IN CONCRETE

1. It is CRITICAL that the jigs are located according to Fig. 3 below and Chart 2 on page 4. The top surface of the jigs MUST be level and flush with the concrete surface. Keep bolt threads and top surface of jig plates clean of concrete. Let concrete cure before installing Meter Tower.

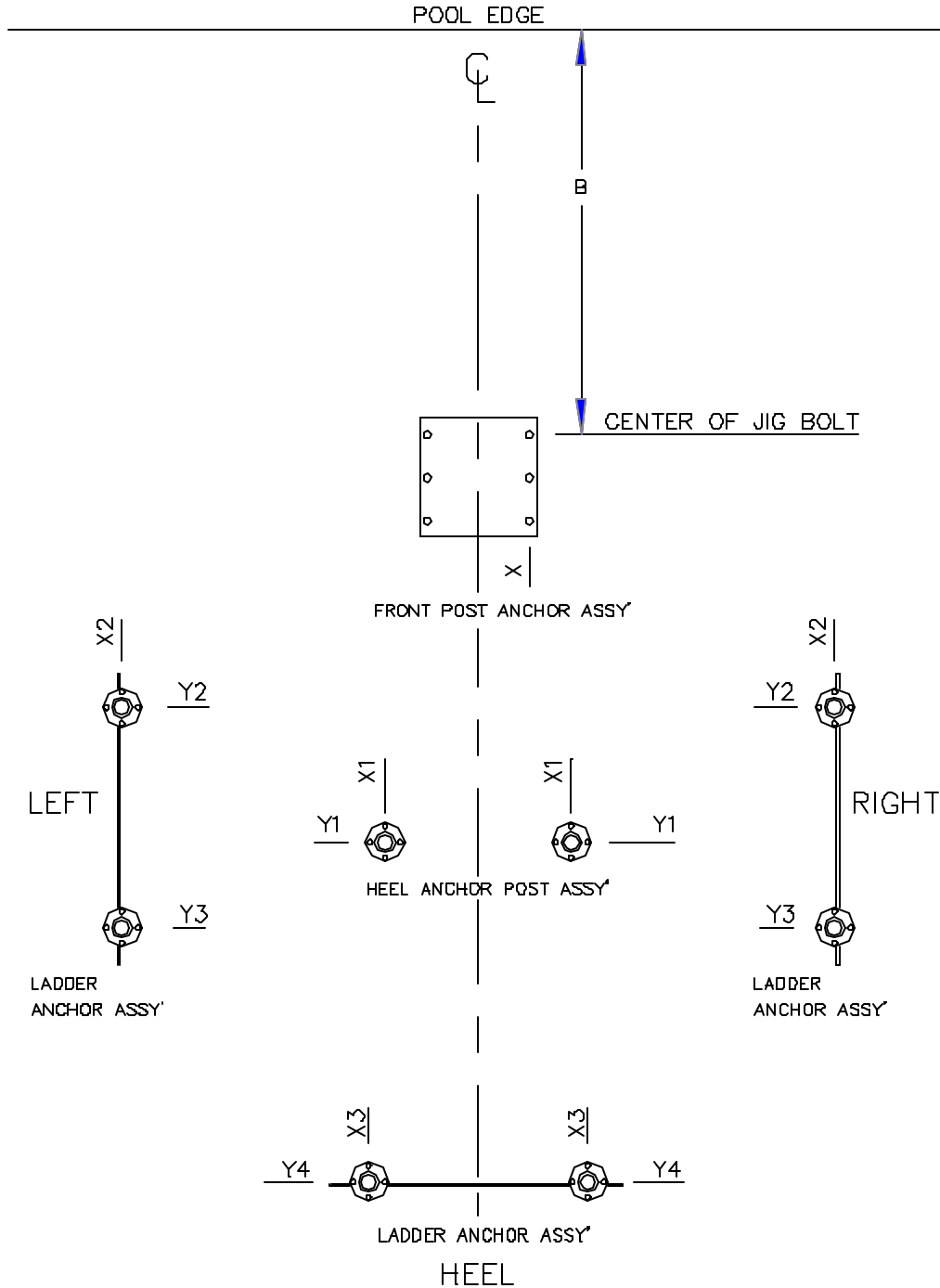

FIG. 3

NOTE: All "Y" dimensions are from the pool's edge and "X" dimensions are from the centerline which is perpendicular to the pool's edge.

CHART 2 JIG PLACEMENT DIMENSIONS

| 1 METER TOWER - 14' BOARD - TYPE VIII POOL | | | | | | | | |
|--|----------|---------|-----------|----------|-----------|-----|-----|------------|
| MOUNT | B* | X1 | Y1 | Y2 | Y3 | X2 | X3 | Y4 |
| RIGHT | 36-5/16" | 11-7/8" | 109-5/32" | 92-1/32" | 120-1/32" | 25" | X | X |
| LEFT | 36-5/16" | 11-7/8" | 109-5/32" | 92-1/32" | 120-1/32" | 25" | X | X |
| DUAL | 36-5/16" | X | X | 92-1/32" | 120-1/32" | 25" | X | X |
| HEEL | 36-5/16" | X | X | X | X | X | 14" | 131-25/32" |

| 1 METER TOWER - 16' BOARD - TYPE VIII POOL | | | | | | | | |
|--|----------|---------|-----------|-----------|-----------|-----|-----|------------|
| MOUNT | B* | X1 | Y1 | Y2 | Y3 | X2 | X3 | Y4 |
| RIGHT | 60-5/16" | 11-7/8" | 133-5/32" | 116-1/32" | 144-1/32" | 25" | X | X |
| LEFT | 60-5/16" | 11-7/8" | 133-5/32" | 116-1/32" | 144-1/32" | 25" | X | X |
| DUAL | 60-5/16" | X | X | 116-1/32" | 144-1/32" | 25" | X | X |
| HEEL | 60-5/16" | X | X | X | X | X | 14" | 155-25/32" |

| 1 METER TOWER - 14' BOARD - TYPE IX POOL | | | | | | | | |
|--|----------|---------|----------|----------|----------|-----|-----|------------|
| MOUNT | B* | X1 | Y1 | Y2 | Y3 | X2 | X3 | Y4 |
| RIGHT | 12-5/16" | 11-7/8" | 85-5/32" | 68-1/32" | 96-1/32" | 25" | X | X |
| LEFT | 12-5/16" | 11-7/8" | 85-5/32" | 68-1/32" | 96-1/32" | 25" | X | X |
| DUAL | 12-5/16" | X | X | 68-1/32" | 96-1/32" | 25" | X | X |
| HEEL | 12-5/16" | X | X | X | X | X | 14" | 107-25/32" |

| 1 METER TOWER - 16' BOARD - TYPE IX POOL | | | | | | | | |
|--|----------|---------|-----------|----------|-----------|-----|-----|------------|
| MOUNT | B* | X1 | Y1 | Y2 | Y3 | X2 | X3 | Y4 |
| RIGHT | 36-5/16" | 11-7/8" | 109-5/32" | 92-1/32" | 120-1/32" | 25" | X | X |
| LEFT | 36-5/16" | 11-7/8" | 109-5/32" | 92-1/32" | 120-1/32" | 25" | X | X |
| DUAL | 36-5/16" | X | X | 92-1/32" | 120-1/32" | 25" | X | X |
| HEEL | 36-5/16" | X | X | X | X | X | 14" | 131-25/32" |

| 3 METER TOWER - 14' BOARD - TYPE IX POOL | | | | | | | | |
|--|---------|---------|----------|----------|----------|-----------|-----|-----------|
| MOUNT | B* | X1 | Y1 | Y2 | Y3 | X2 | X3 | Y4 |
| RIGHT | 33-1/4" | 11-7/8" | 85-5/32" | 68-1/32" | 96-1/32" | 45-15/32" | X | X |
| LEFT | 33-1/4" | 11-7/8" | 85-5/32" | 68-1/32" | 96-1/32" | 45-15/32" | X | X |
| DUAL | 33-1/4" | X | X | 68-1/32" | 96-1/32" | 45-15/32" | X | X |
| HEEL | 33-1/4" | X | X | X | X | X | 14" | 128-7/16" |

| 3 METER TOWER - 16' BOARD - TYPE IX POOL | | | | | | | | |
|--|---------|---------|-----------|----------|-----------|-----------|-----|-----------|
| MOUNT | B* | X1 | Y1 | Y2 | Y3 | X2 | X3 | Y4 |
| RIGHT | 57-1/4" | 11-7/8" | 109-5/32" | 92-1/32" | 120-1/32" | 45-15/32" | X | X |
| LEFT | 57-1/4" | 11-7/8" | 109-5/32" | 92-1/32" | 120-1/32" | 45-15/32" | X | X |
| DUAL | 57-1/4" | X | X | 92-1/32" | 120-1/32" | 45-15/32" | X | X |
| HEEL | 57-1/4" | X | X | X | X | X | 14" | 152-7/16" |

* Same as "B" dimension in Fig. 2 page 2 and Fig 3 page 3.

ASSEMBLING METER TOWER

2. Assemble stainless steel Treads to Ladder Posts with hardware according to Fig. 4. Hand tighten only.

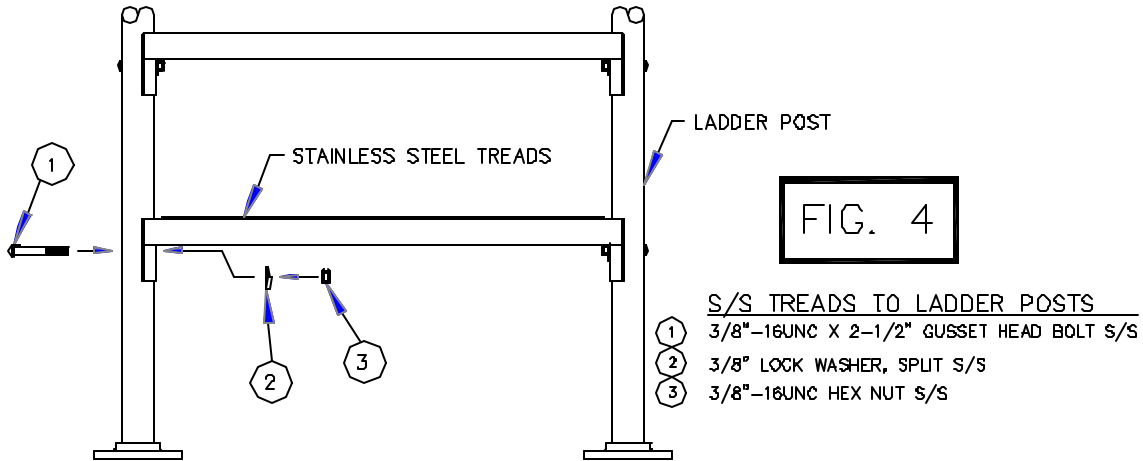

3. (Dual Mount Tower Only) Assemble the Dual Mount Tray Handrail with hardware to the two Ladder Assemblies according to Fig. 5. Hand tighten only.

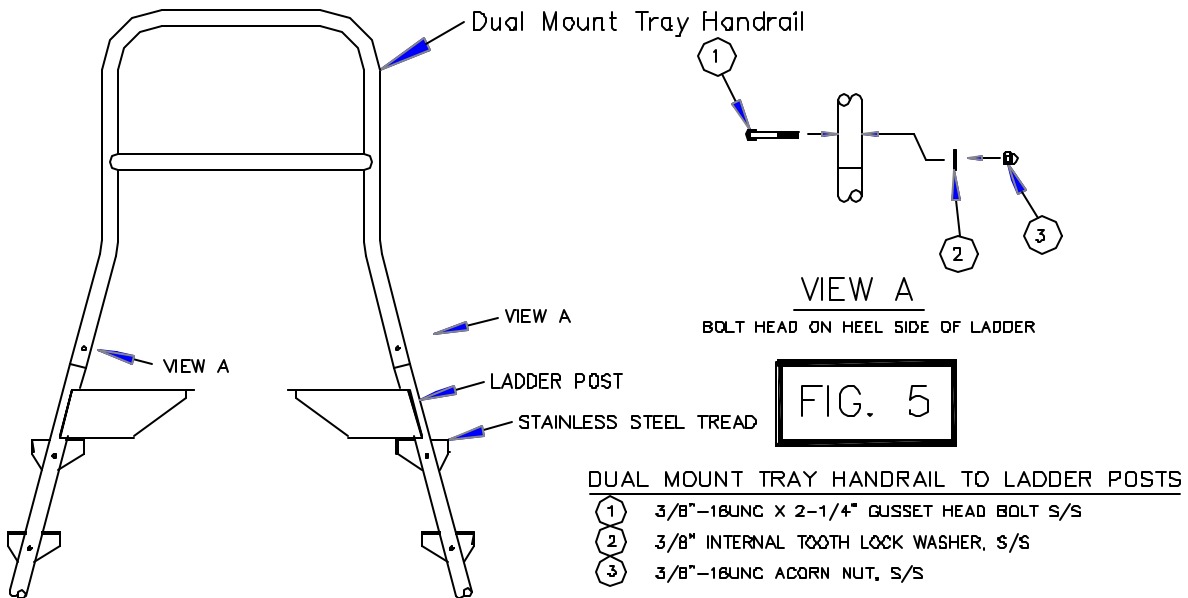

4. Install Front Post Assembly with hardware to jig according to Fig. 6. Ensure that rubber gasket is in place. Tighten hardware between 40 and 50 ft. lbs.

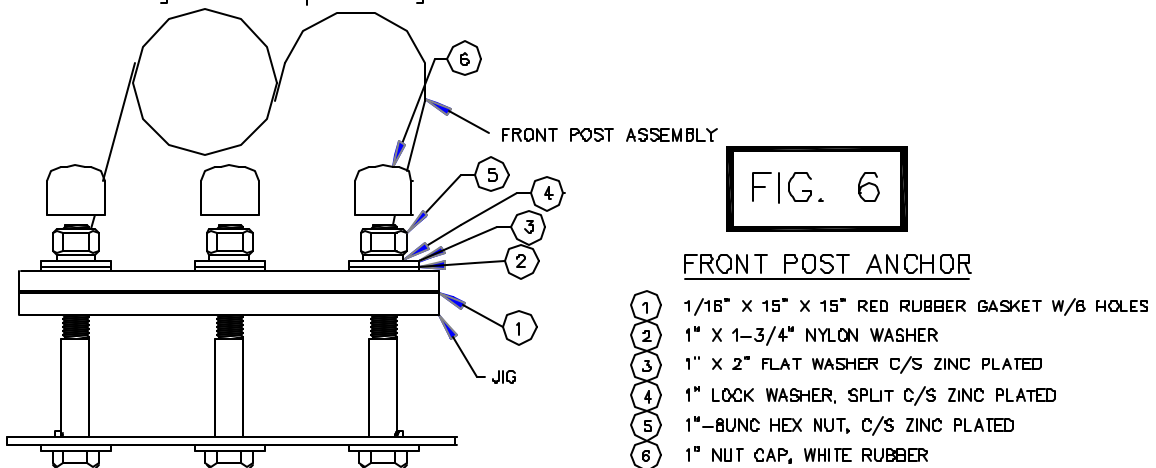

- 5 Install Ladder Assembly and Heel Post Assembly with hardware to respective jigs according to Fig. 7. Make sure gaskets are in place. Hand tighten only.

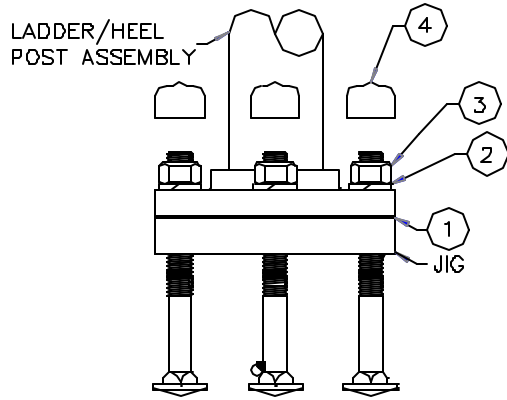

FIG. 7

LADDER & POST ANCHORS

- 1 1/16" X 5" DIA, RED RUBBER GASKET
- 2 1/2" LOCK WASHER, SPLIT C/S ZINC PLATED
- 3 1/2"-13UNC HEX NUT, C/S ZINC PLATED
- 4 1/2" PLASTIC NUT CAP

- 6 Place gaskets on top of the Ladder Brackets, Front Post Plate and Heel Post Flange. Place Tray on these gaskets and align holes in Tray with the holes in the Front Post Plate. Assemble with hardware according to Fig. 8. Align holes in Ladder Brackets and Heel Post Flange with the holes in the Tray. Assemble with hardware according to Fig. 9 and 10. See step 7 for tightening schedule.

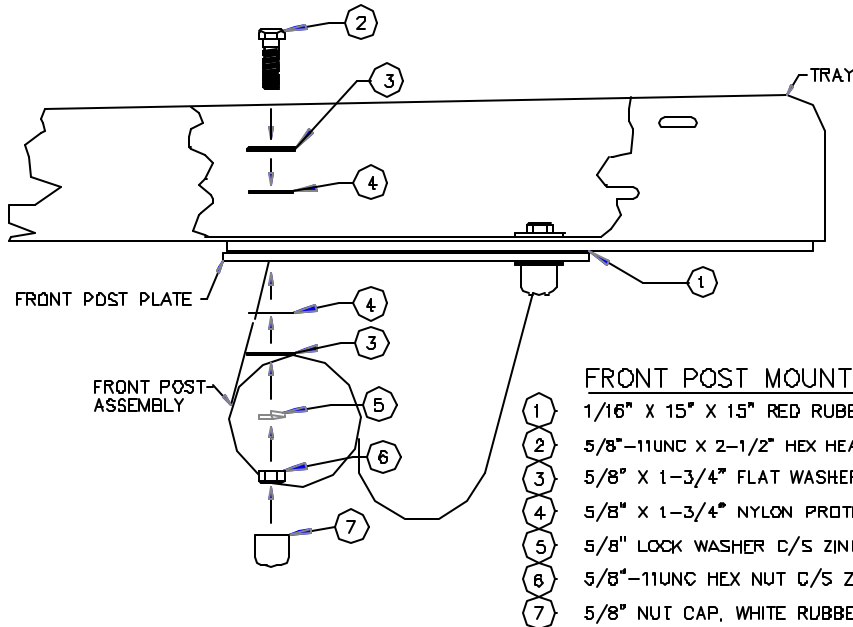

FIG. 8

FRONT POST MOUNT

- 1 1/16" X 15" X 15" RED RUBBER GASKET W/ 4 HOLES
- 2 5/8"-11UNC X 2-1/2" HEX HEAD BOLT GRADE 5 C/S ZINC PLATED
- 3 5/8" X 1-3/4" FLAT WASHER C/S ZINC PLATED
- 4 5/8" X 1-3/4" NYLON PROTECTIVE WASHER
- 5 5/8" LOCK WASHER C/S ZINC PLATED
- 6 5/8"-11UNC HEX NUT C/S ZINC PLATED
- 7 5/8" NUT CAP, WHITE RUBBER

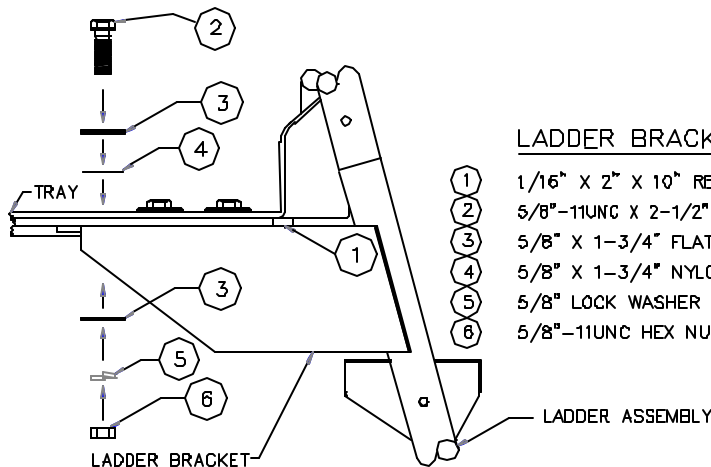

FIG. 9

LADDER BRACKET MOUNT

- 1 1/16" X 2" X 10" RED RUBBER GASKET
- 2 5/8"-11UNC X 2-1/2" HEX HEAD BOLT GRADE 5 C/S ZINC PLATED
- 3 5/8" X 1-3/4" FLAT WASHER C/S ZINC PLATED
- 4 5/8" X 1-3/4" NYLON PROTECTIVE WASHER
- 5 5/8" LOCK WASHER C/S ZINC PLATED
- 6 5/8"-11UNC HEX NUT C/S ZINC PLATED

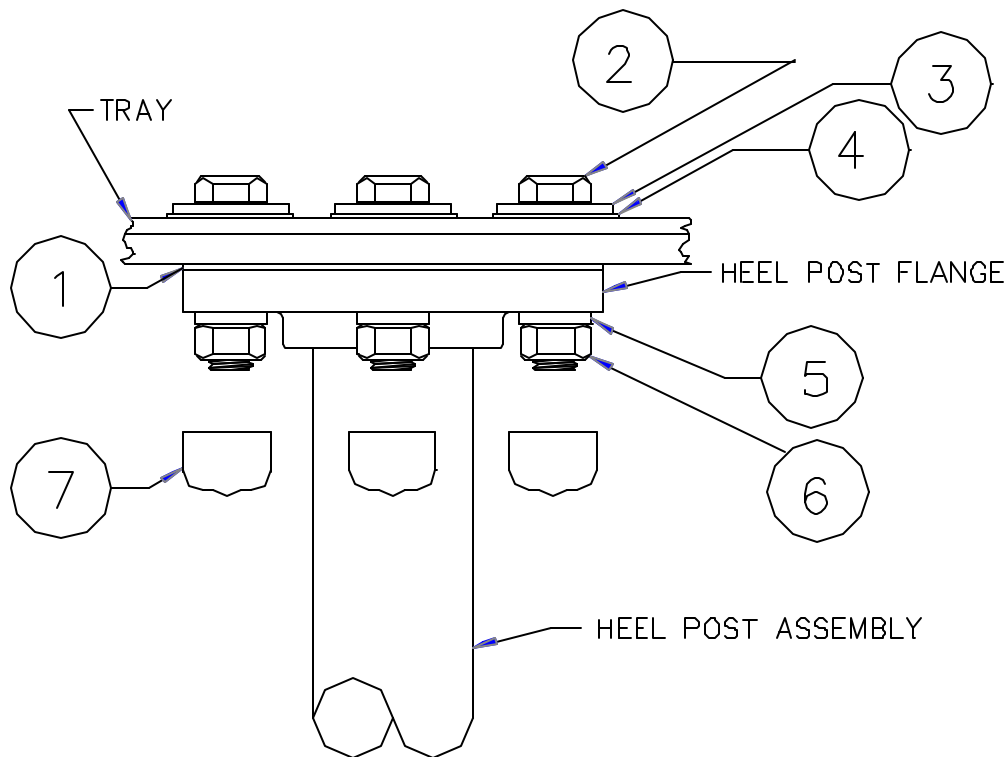

FIG. 10

HEEL POST MOUNT

- ① 1/16" X 5" DIA. RED RUBBER GASKET
- ② 1/2"-13UNC X 2" HEX HEAD CAP SCREW, C/S ZINC PLATED
- ③ 1/2" X 1-3/8" FLAT WASHER, C/S ZINC PLATED
- ④ 1/2" X 1-1/2" ROUND NYLON WASHER
- ⑤ 1/2" LOCK WASHER, SPLIT C/S ZINC PLATED
- ⑥ 1/2"-13UNC HEX NUT, C/S ZINC PLATED
- ⑦ 1/2" PLASTIC NUT CAP

-
7. Tighten hardware connecting Front Post Assembly, Ladder Brackets and Heel Post Assembly to the Tray between 40 and 50 ft. lbs. Then tighten hardware connecting Ladder Assembly and Heel Post Assembly to jigs between 40 and 50 ft. lbs. Now tighten hardware connecting Treads and Dual Tray Handrail (if applicable) to Ladder Posts between 15 and 20 ft. lbs. Do not over tighten.
-

8. Install Tray Handrails to Tray and Ladder Assembly according to Fig. 11 using hardware tightened between 15 and 20 ft. lbs. Do not over tighten.

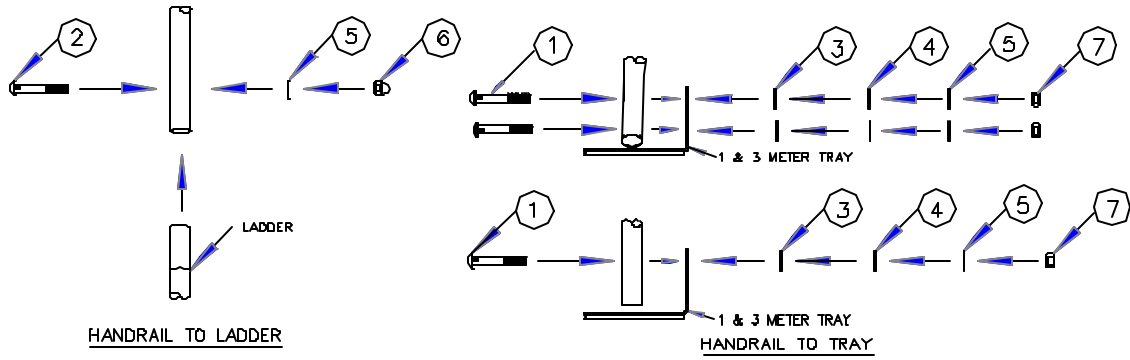

FIG. 11

TRAY HANDRAIL TO LADDER AND TRAY

- ① 3/8"-16UNC X 2-1/2" GUSSET HEAD BOLT, S/S
- ② 3/8"-16UNC X 2-1/4" GUSSET HEAD BOLT, S/S
- ③ 3/8" X 7/8" NYLON PROTECTIVE WASHER
- ④ 3/8" X 7/8" FLAT WASHER, S/S
- ⑤ 3/8" INTERNAL TOOTH LOCK WASHER, S/S
- ⑥ 3/8"-16UNC ACORN NUT, S/S
- ⑦ 3/8"-16UNC HEX NUT, S/S

9. (3 Meter Tower Only) Snap Ladder Handrail Assembly onto Ladder Posts and Tray Handrails as shown in Fig. 12. Drill 7/16" diameter holes through existing holes in Ladder Handrail Brackets through the Ladder Posts and Tray Handrails. Grind down any sharp edges or burrs. Assemble with hardware and tighten between 15 and 20 ft. lbs. Do not over tighten.

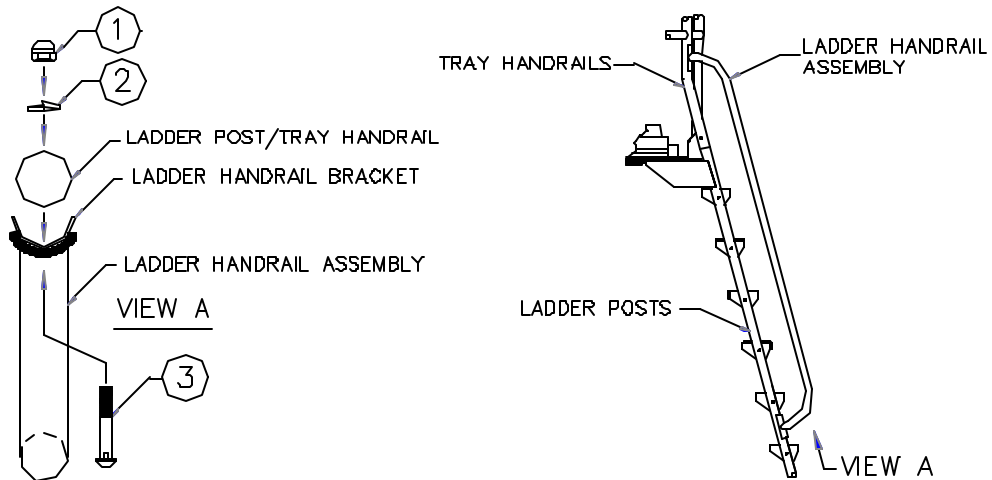

FIG. 12

LADDER HANDRAIL TO LADDER POSTS/TRAY HANDRAIL

- ① 3/8"-16UNC ACORN NUT S/S
- ② 3/8" LOCK WASHER, SPLIT S/S
- ③ 3/8"-16UNC X 2-1/2" GUSSET HEAD BOLT S/S

10. Assemble Tie Down Assembly to Tray according to Fig. 13 using hardware tightened between 40 and 50 ft. lbs. Do not over tighten.

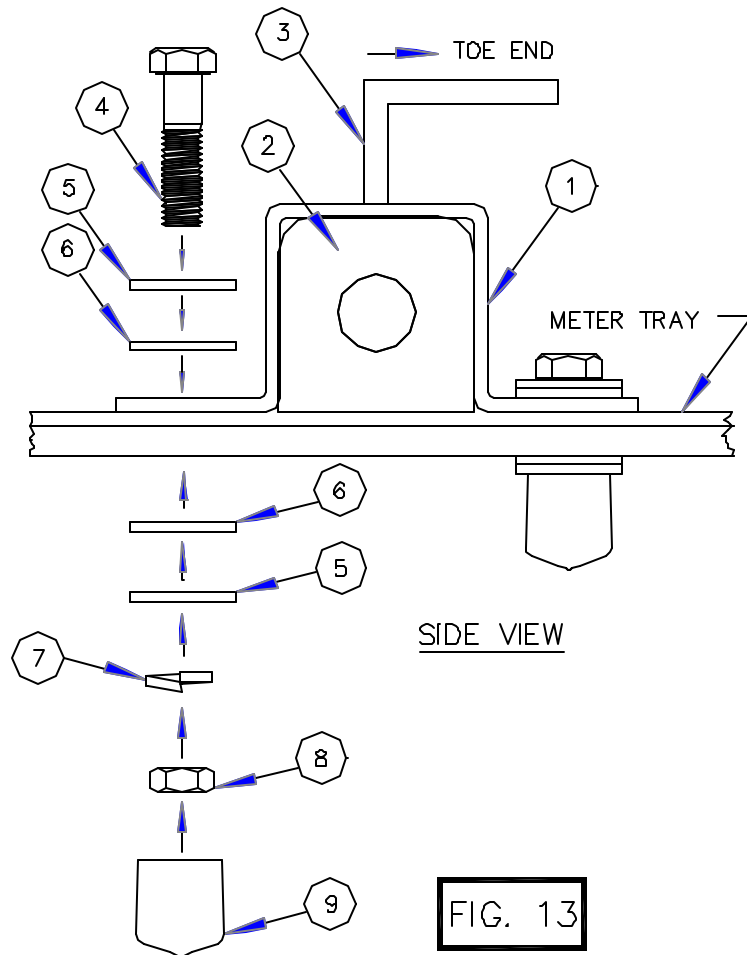
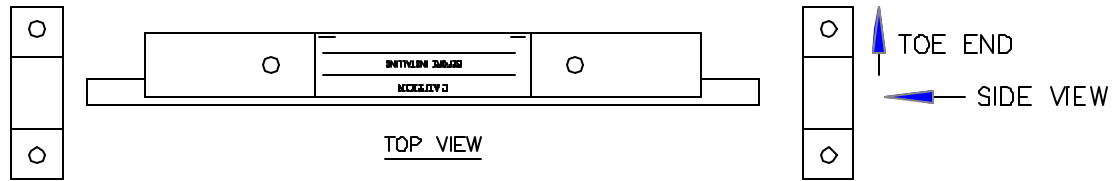

FIG. 13

TIE DOWN ASSEMBLY

- ① TIE-DOWN STRAP (PRIMED)
- ② URETHANE BLOCK
- ③ TIE-DOWN ANGLE ASSY'
- ④ 1/2"-13UNC X 2" HEX HEAD CAP SCREW, C/S ZINC PLATED
- ⑤ 1/2" X 1-3/8" FLAT WASHER, C/S ZINC PLATED
- ⑥ 1/2" X 1-1/2" ROUND NYLON WASHER
- ⑦ 1/2" LOCK WASHER, SPLIT C/S ZINC PLATED
- ⑧ 1/2"-13UNC HEX NUT, C/S ZINC PLATED
- ⑨ 1/2" PLASTIC NUT CAP

INSTALLATION OF THE QUICK ADJUSTABLE FULCRUM

11.

Place the Gear Rack Assembly over the line of eight 1/2" diameter holes on the left side of the Tray. Use the hole closest to the toe end of the Tray for S.R. Smith's 14' and 16' Commercial Diving Boards. Secure the Gear Rack Assembly according to Fig. 14 and hand tighten only. Place the other Gear Rack Assembly over the right side holes with the Fulcrum Axle Assembly inbetween. Make sure the gears mesh with and are perpendicular to the gear rack and that the Ratchet Housing is on the right side. Secure the Gear Rack Assembly to the Tray using hardware tightened between 20 and 30 ft. lbs. Do not over tighten.

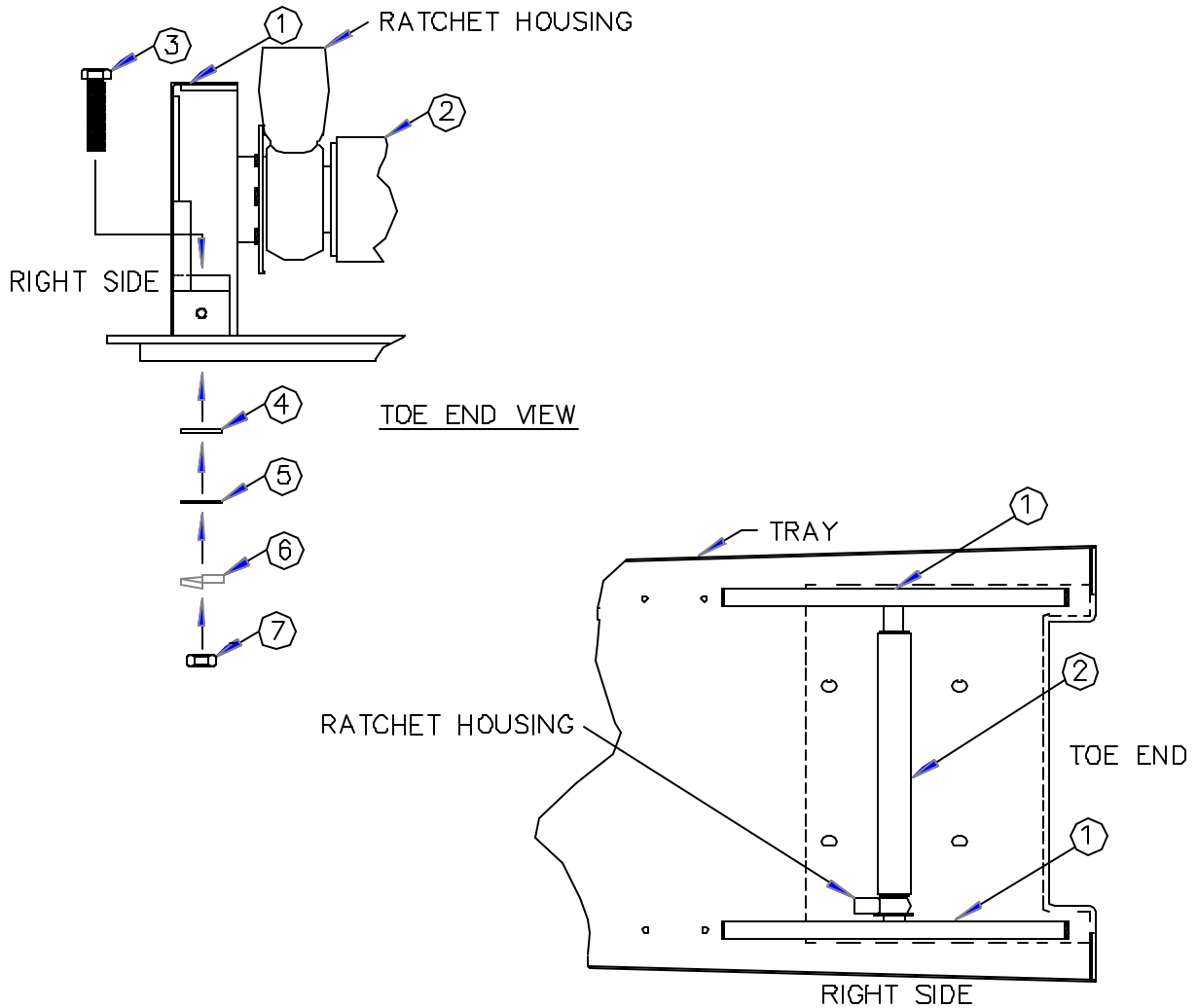

FIG. 14

QUICK ADJUSTABLE FULCRUM

- ① GEAR RACK ASSEMBLY
- ② FULCRUM AXLE ASSEMBLY
- ③ 3/8"-16UNC X 2" HEX HEAD CAP SCREW S/S
- ④ 3/8" X 7/8" NYLON PROTECTIVE WASHER
- ⑤ 3/8" X 7/8" FLAT WASHER S/S
- ⑥ 3/8" LOCK WASHER, SPLIT S/S
- ⑦ 3/8"-16UNC HEX NUT S/S

12. Stick the Fulcrum Adjustment Label over the Gear Rack Cover as shown in Fig. 15. Insert the Ratchet Handle Assembly into the Ratchet Housing and tap roll pin through the holes to secure.

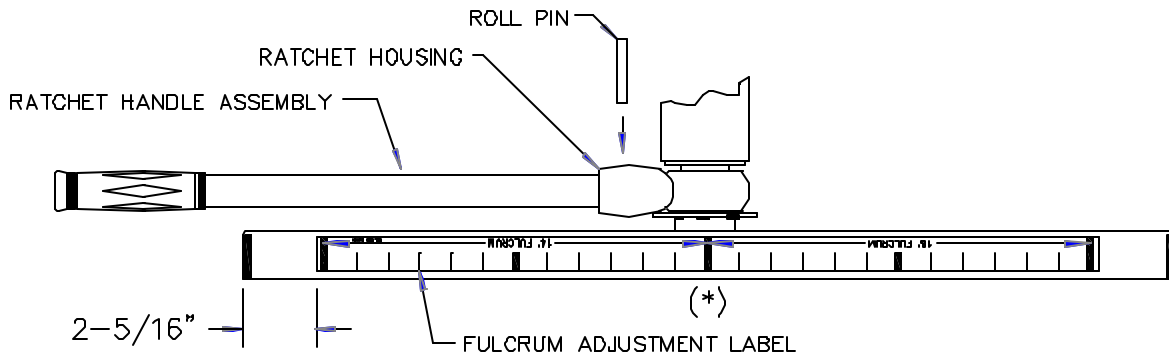

FIG. 15

13. Stick the Tray Fulcrum Adjustment Label on the right outside wall of the Tray as shown in Fig. 16 with the centerline of the Tray Fulcrum Adjustment Label (*) aligned with the centerline of the Fulcrum Adjustment label (*) as indicated in Fig. 15.

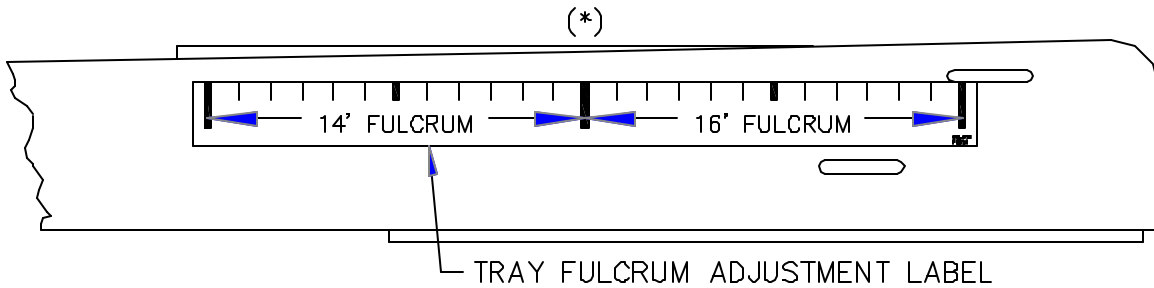

FIG. 16

INSTALL DIVING BOARD

14. Secure the Diving Board to the Tie Down Assembly according to Fig. 17 and tighten hardware between 20 and 25 ft. lbs. Do not over tighten.

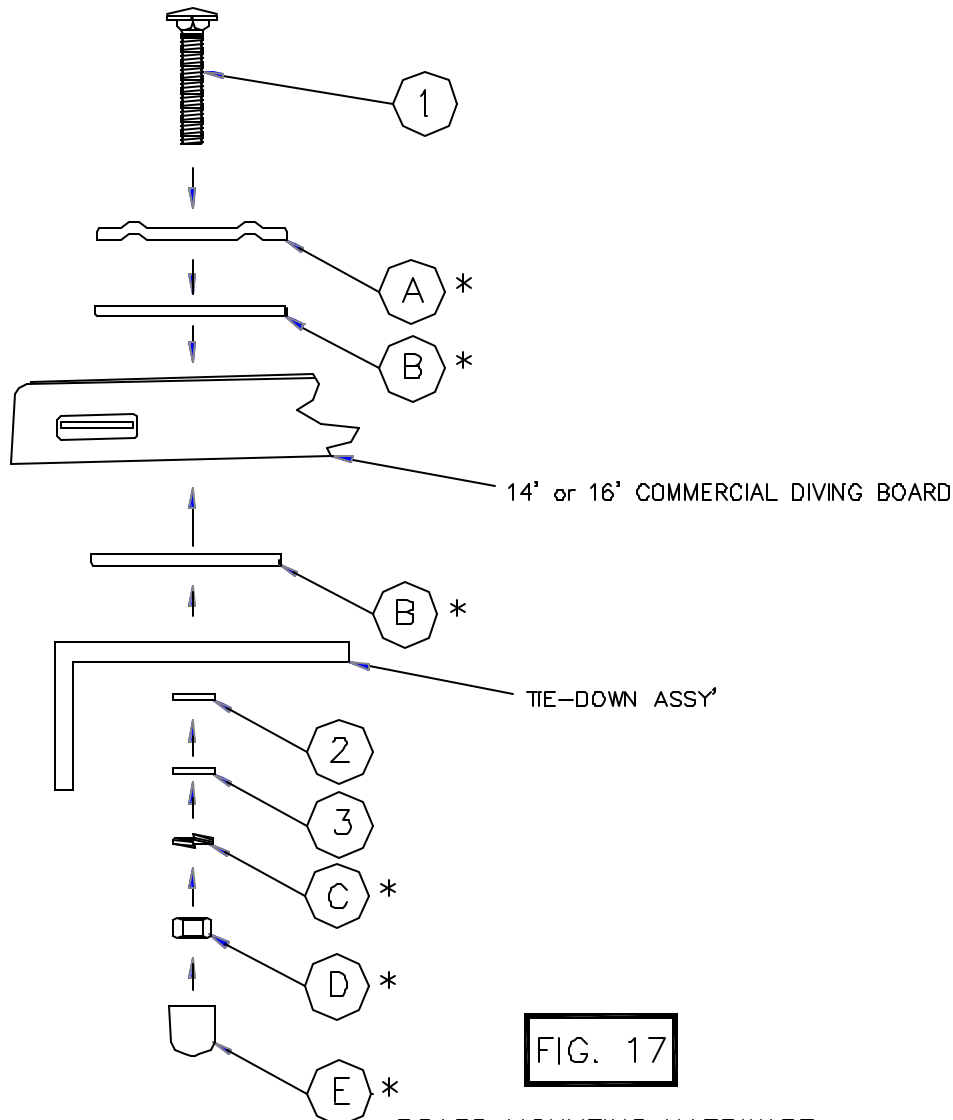

FIG. 17

BOARD MOUNTING HARDWARE

(INCLUDED IN 1 & 3 METER TOWER HARDWARE KIT)

- ① 1/2" X 4" CARRIAGE BOLT GRADE 5 C/S ZINC PLATED
- ② 1/2" X 1-1/2" ROUND NYLON WASHER
- ③ 1/2" X 1-3/8" FLAT WASHER C/S ZINC PLATED

* HARDWARE LOCATED IN THE 20" COMMERCIAL MOUNTING KIT
Included with 14' and 16' Commercial Diving Boards.

- Ⓐ 20" TOP MOUNTING PLATE
- Ⓑ 20" RUBBER MOUNTING PAD
- Ⓒ 1/2" LOCK WASHER C/S ZINC PLATED
- Ⓓ 1/2" HEX NUT C/S ZINC PLATED
- Ⓔ 1/2" PLASTIC NUT CAP

16. Check to ensure compliance with ANSI/NSPI-1 1991 STANDARD FOR PUBLIC SWIMMING POOLS. Adjust the fulcrum according to Chart 1 Rule Sheet on page 2.

17. ONLY ONE PERSON ON DIVING BOARD AT A TIME, WITH A MAXIMUM WEIGHT OF 250 LBS.

**EXTRACTED from the ANSI/NSPI-1 1991
STANDARD FOR PUBLIC SWIMMING POOLS**

STATEMENT

This voluntary standard has been developed under the published procedures of the American National Standards Institute. The National Spa and Pool Institute, its members, and those participating in its activities do not accept any liability resulting from compliance or noncompliance with the provisions given herein, for any restrictions imposed on materials, or for the completeness of the text.

The NSPI does not monitor or enforce compliance with the contents of this document and any certification of products stating compliance with requirements of this document are the sole responsibility of the certifier.

It is assumed and intended that pool users will exercise appropriate personal judgment and responsibility and that public pool owners and operators will create and enforce rules of behavior and warnings appropriate for their facility.

ARTICLE I

1. SCOPE

- 1.2 This standard is not meant to cover pools for competitive diving or swimming, permanently installed residential pools, aboveground/onground pools, portable spas, hot tubs, or other pools or spas, such as those operated for medical treatment, physical therapy, or other special purposes.

DEFINITIONS

COMMERCIAL/PUBLIC POOL

Any pool, other than a residential pool, which is intended to be used for swimming or bathing and is operated by an owner, lessee, operator, licensee or concessionaire, regardless of whether a fee is charge for use. References within the standard to various types of public pools are defined by the following categories:

CLASS A: COMPETITION POOL – Any pool intended for use for accredited competitive aquatic events such as Federation Internationale de Natation Amateur (FINA), U.S. Swimming, U.S. Diving, National Collegiate Athletic Association (NCAA), National Federation of State High School Associations (NFSHSA), etc. The pool may also be used for recreation.

CLASS B: PUBLIC POOL – Any pool intended for public recreational use.

CLASS C: SEMI-PUBLIC POOL – Any pool operated solely for and in conjunction with lodgings such as hotels, motels, apartments, condominiums, etc.

CLASS D: OTHER POOL – Any pool operated for medical treatment, therapy, exercise, lap swimming, recreational play, and other special purposes, including, but not limited to, wave or surf action pools, activity pools, splash pools, kiddie pools and play areas. These pools are not intended to be covered within the scope of NSPI standards.

Public pools may be diving or nondiving. If diving, they shall be further classified into types as an indication of the suitability of a pool for use with diving equipment.

TYPE VI-IX: Public pools suitable for the installation of diving equipment by type. Diving equipment classified at a higher type may not be used on a pool of lesser type (i.e., Type VIII equipment on a Type VI pool).

TYPE N. A non-diving public pool (no diving allowed).

ARTICLE IV

4. DIMENSIONAL DESIGN

- 4.1.2 There shall be construction tolerances allowed on all dimensional designs. Overall length, width, and depth in the deep end may vary plus or minus three inches ($\pm 3''$). All other overall dimensions may vary plus or minus two inches ($\pm 2''$), unless otherwise specified (such as in a Class A pool). The designed waterline shall have a maximum construction tolerance at the time of completion of the work of plus or minus one-fourth inch ($\pm 1/4''$) for pools with adjustable weir surface skimming systems, and of plus or minus one-eighth inch ($\pm 1/8''$) for pools with nonadjustable surface skimming systems.
- 4.2 WALLS: Walls in Class B and C pools shall not be greater than 11' from plumb (see Article 4.6.2) for a minimum depth of two feet nine inches (2'9") from the waterline in deep areas, or two feet three inches (2'3") in the shallow areas. Below these depths, the wall may be radiused to join the floor. Class A pools, where racing lanes terminate, shall have plumb walls. (A maximum 1' from plumb construction tolerance shall be allowed.)
- 4.3 FLOOR SLOPES: Floor slopes shall, as a minimum, be in compliance with Article 4.3.1 through 4.3.5.
- 4.3.1 All slopes shall be uniform.
- 4.3.2 The slope of the floor from the shallow end wall towards the deep end shall not exceed one foot in twelve feet (1':12') to the point of the first slope change for Class A and B pools, or one foot in ten feet (1':10') for Class C pools.
- 4.3.3 The point of the first slope change shall be defined as the point at which the floor slope exceeds one foot in twelve feet (1':12') for Class A and B pools, or one foot in ten feet (1':10') for Class C pools.
- 4.3.4 The slope of the floor from the point of the first slope change to the deep end shall not exceed one foot in three feet (1':3'). Such slopes are not intended to provide any less water depth than those specified if the pool is intended for diving.
- 4.3.5 Transitional radius from wall to floor where floor slopes join the wall shall comply with Articles 4.3.5.1 through 4.3.5.3.
- 4.3.5.1 The radius shall have its center no less than two feet nine inches (2'9") below the waterline in deep areas or two feet six inches (2'6") in the shallow area.
- 4.3.5.2 The radius shall be tangent at the point where the radius either meets the wall or the floor.
- 4.3.5.3 The radius shall be at least equal to, or greater than, the depth of the pool minus the vertical wall depth measured from the waterline (or tolerance allowed in Article 4.2) minus three inches ($-3''$) to allow draining to the main drain. (R minimum = Pool depth - Vertical wall depth - 3")
- 4.5 DIVING: Diving intended for Class B and C pools shall conform to the minimum water depths, areas, slopes, and other dimensions shown in Article 4.6.1. If a wall exists, then it shall conform with the 3:1 slope in the Point D dimension and the L₁₋₂₋₃₋₄ dimensions
- 4.5.1 When diving equipment is installed, it shall conform to the specifications set forth in Article 5.7 and shall be located in the diving area of the pool so as to provide the minimum dimensions as shown in Article 4.6.1. Competitive diving equipment shall not be installed on Class B and C pools.
- 4.5.2 The tip of the diving equipment shall be located at Point A, which is the reference point of all other dimensions.
- 4.5.3 There shall be a completely unobstructed clear vertical distance of thirteen feet (13') above any diving board measured from the center of the front end of the board. This area shall extend horizontally at least eight feet (8') behind, eight feet (8') to each side and sixteen feet (16') ahead of Point A.
- 4.5.4 Public pools with diving facilities in excess of three (3) meters in height, or pools designed for platform diving, shall comply with the dimensional design requirements of FINA, U.S. Diving, National Federation of State High School Associations (NFSHSA), etc.
-

4.6 DRAWINGS AND DIAGRAMS

4.6.1 MINIMUM DIMENSIONS FOR DIVING PORTION OF CLASS B AND C POOLS

(This drawing does not show the shallow portion of the pool)

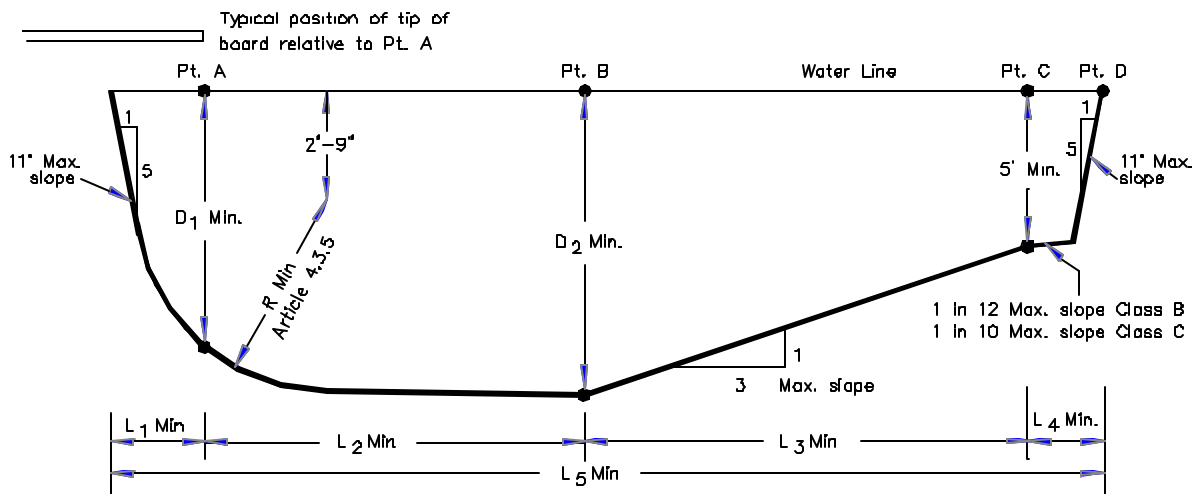

NOTE: L_4 is a minimum dimension to allow sufficient length opposite the board.
This may of course be lengthened to form the shallow portion of the pool.

| POOL TYPE | RELATED DIVING EQUIPMENT | | MINIMUM DIMENSIONS | | | | | | | | MINIMUM WIDTH OF POOL AT: | | |
|-----------|--------------------------|-----------------------------|--------------------|--------|-------|-------|--------|--------|-------|--------|---------------------------|--------|--------|
| | MAX. DIVING BOARD LENGTH | MAX BOARD HEIGHT OVER WATER | D_1 | D_2 | R | L_1 | L_2 | L_3 | L_4 | L_5 | PT.A | PT.B | PT.C |
| VI | 10' | (2/3 Meter) 26" | 7'-0" | 8'-6" | 5'-6" | 2'-6" | 8'-0" | 10'-6" | 7'-0" | 28'-0" | 18'-0" | 18'-0" | 18'-0" |
| VII | 12' | (3/4 Meter) 30" | 7'-6" | 9'-0" | 6'-0" | 3'-0" | 9'-0" | 12'-0" | 4'-0" | 28'-0" | 18'-0" | 20'-0" | 20'-0" |
| VIII | 16' | 1 Meter | 8'-6" | 10'-0" | 7'-0" | 4'-0" | 10'-0" | 15'-0" | 2'-0" | 31'-0" | 20'-0" | 22'-0" | 22'-0" |
| IX | 16' | 3 Meter | 11'-0" | 12'-0" | 8'-6" | 6'-0" | 10'-6" | 21'-0" | 0 | 37'-6" | 22'-0" | 24'-0" | 24'-0" |

L_2 , L_3 , and L_4 combined represent the minimum distance from the tip of board to pool wall opposite diving equipment.

For board heights exceeding 3 meters see Article 4.5.2.

*NOTE: Placement of boards shall observe the following minimum dimensions. With multiple board installations minimum pool widths must be increased accordingly.

| | |
|--|-----|
| Deck Level Board to Pool Side | 8' |
| 1 Meter Board to Pool Side | 10' |
| 3 Meter Board to Pool Side | 11' |
| 1 Meter or Deck Level Board to 3 Meter Board | 10' |
| 1 Meter or Deck Level Board to another 1 Meter or Deck Level Board | 8' |
| 3 Meter to another 3 Meter Board | 10' |

4.6.2 MAXIMUM ALLOWABLE WALL SLOPE

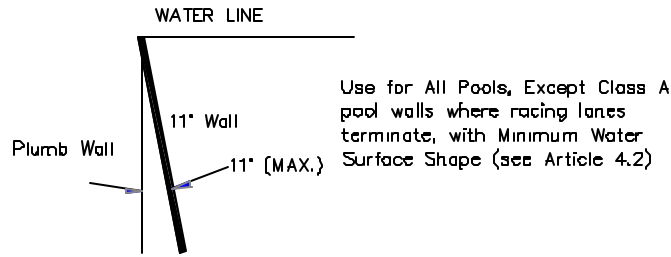

- 4.7 **OFFSET LEDGES:** Offset ledges, when provided, shall fall within 11" from plumb starting at the junction of the pool wall and waterline, and shall have a slip-resisting surface. Maximum width shall be eight inches (8"). The typical allowable dimensions are based on the depths shown below:

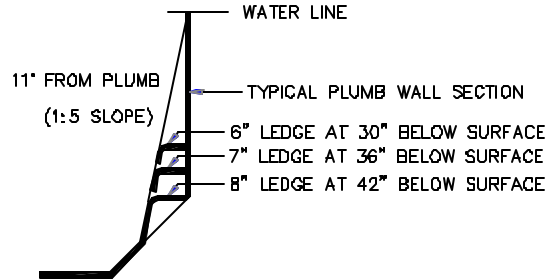

- 4.8 **UNDERWATER SEAT BENCHES:** Underwater seat benches, when provided, shall have a maximum horizontal seat bench depth of twenty inches (20") below the waterline, be visually set apart, have a slip-resisting surface, and shall be located fully outside of the required minimum diving water envelope if the pool is intended for use with diving equipment.
- 4.8.1 Underwater seat benches shall be permitted in the deep end of the pool only if they are either completely recessed, shaped to be compatible with the shape of the pool wall, or in a corner of the pool
- 4.9 **MAXIMUM USER LOAD:** Maximum user load at Class B or C pools shall be 300 square feet in Diving Area (per each diving board).

ARTICLE V

5. DECKS AND DECK EQUIPMENT

- 5.7.3 Diving equipment suitable for installation on a lower pool type may be installed on any higher pool type providing no less a water envelope is provided from the tip of the board than called for in the lower type. Diving equipment of a greater type, e.g., Type VIII, shall not be installed on a pool of lesser type, e.g., Type VII. Should diving equipment be installed at any greater height than specified for the lower type pool, water surface area and geometry shall be provided for the type pool which permits board installation at that height.
- 5.7.5 Diving equipment shall be permanently anchored to the pool deck. The edge of the board at the tip end shall be level with the water surface. The tip end of the board over the pool water surface may be higher than the butt end of the board. Refer to manufacturer's recommendations.
- 5.7.6 Maximum board height over the water shall have plus three inches (+3") tolerance to allow for construction variances only on Class B and C pools.
- 5.7.7 The maximum construction tolerance of the tip of the board from Point A shall be plus or minus three inches ($\pm 3"$) on Class B and C pools. The diving equipment shall be in compliance with Article 4.5.2.
-