

AG19

10' cantilever umbrella

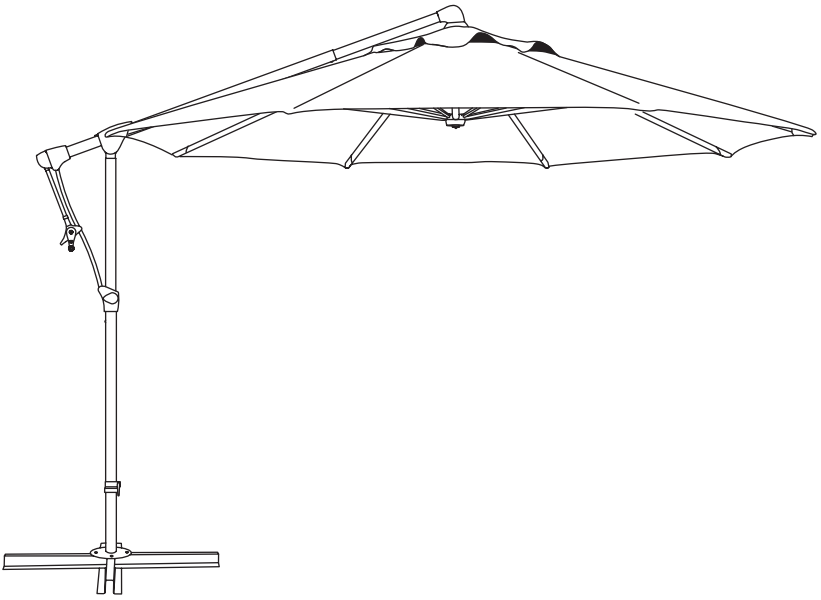

ASSEMBLY AND OPERATION

 **TREASURE[®]
GARDEN, INC.**

Thank you for your purchase of **Treasure Garden's AG19** cantilever umbrella. Please remove all contents from the package, inspect and review checklist for all parts. **CAUTION:** To reduce personal injury and damage to your umbrella, read and follow this Assembly and Operation information.

C H E C K L I S T :

- | | | |
|-----------------------------|----------------------------|--------------------------------|
| A - Spring Locks (2) | G - Support Strut | L - Cantilever |
| B - Top Pole | H - Opening Stop | M - Vega™ Light Adapter |
| C - Crank | I - Release Handle | N - Canopy |
| D - Operating Handle | J - Bottom Pole | |
| E - Crank Case | K - Base Pole Clamp | |
| F - Steering Rod | | |

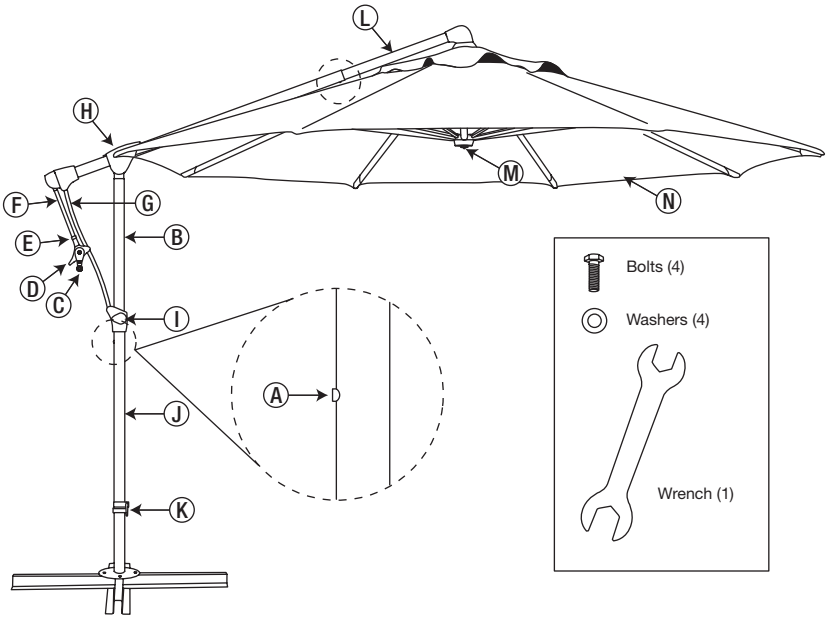

R E Q U I R E D F O R A S S E M B L Y :

- One (1) 1/2" socket wrench or adjustable wrench.
- Four (4) 50 lb. weights - square stones or concrete weights. (200 lb. total weight needed for support - weights not included) Stones & weights, standard sizes can be used up to 20" L x 20" W x 1-5" H.

NOTE: Using the stand without weights will damage your umbrella.

ASSEMBLY :

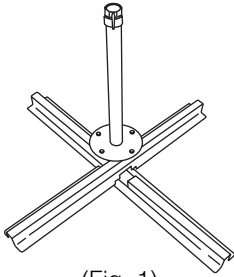

(Fig. 1)

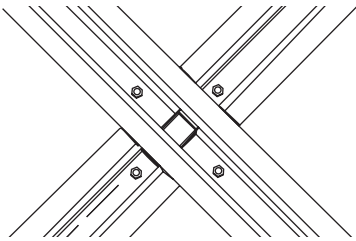

(Fig. 2)

To ASSEMBLE Cross Bar Stand:

1. Set cross bars in a cross position and attach bottom pole stem (Fig. 1) to cross bar stand with supplied nuts and bolts (Fig. 2).
2. Secure with (4) square stones or concrete weights (weights not included).

IMPORTANT: Cross bar stand will not support umbrella without proper weights. Using the stand without weights will damage your umbrella.

To ASSEMBLE AG19 Frame:

1. Connect the bottom pole to the top pole while on the ground (Fig. 3). Press the spring locks and continue to slide the bottom pole until it locks in place.
 2. Lift the AG19 up and insert it into the base.
 3. Hold the closed shade and slowly move it upwards until the spring locks lock into place (Fig. 4) (if this does not happen, it may be because the cord is coiled too tightly).
- NOTE:** Two persons are needed for the following action. While the first person slowly lifts up the shade, the second person turns the crank counter-clockwise, thereby releasing more cord to allow the shade to raise until it locks into place.
4. Screw the crank clockwise into the crank case.

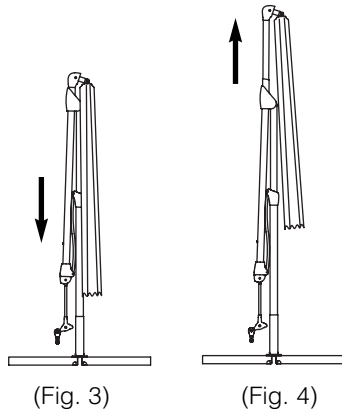

(Fig. 3)

(Fig. 4)

IMPORTANT: Shortening of the cantilever is merely for transport purposes. This operation should not be performed again (Fig. 4).

OPERATION :

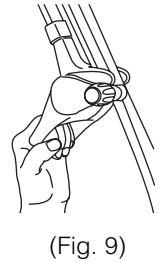
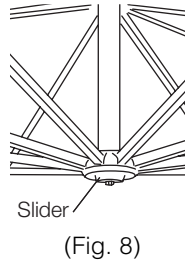
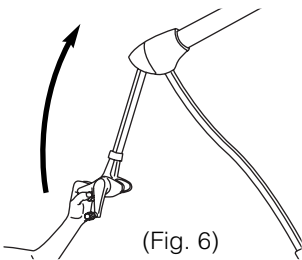
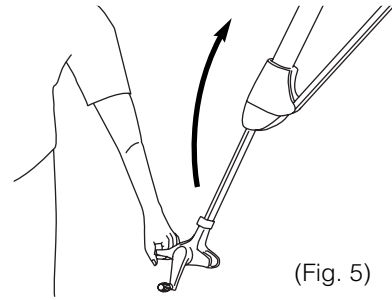

TO OPEN AG19

1. Hold the operating handle (Fig. 5) on the cantilever and push it up until the opening stop is reached (Fig. 6).
2. Turn the crank (Fig. 7) clockwise until the umbrella is fully opened and the slider (Fig. 8) is at the top most position.
3. Lock the umbrella by attaching the crank case to the support strut (Fig. 9).

To CLOSE AG19

IMPORTANT: When closing the umbrella, the canopy must be in a horizontal position, or damage to umbrella may occur.

1. Hold the operating handle (Fig. 10) and turn the crank counter-clockwise until the canopy is closed.
2. Turn the release handle clockwise; at the same time, pull the cantilever back using the operating handle (Fig. 11) and guide the cantilever back to the pole.

- CAUTION:** Avoid pinching hands or fingers while closing the umbrella.
3. Now close the frame and cover it with a protective cover (sold separately).

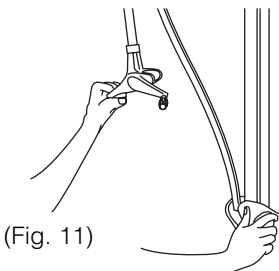
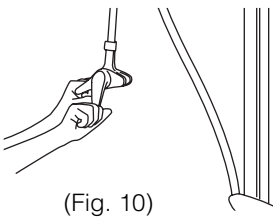

To TURN the umbrella around the pole axis

1. Loosen the base pole clamp by turning the clamp counter-clockwise. Turn the umbrella to the desired position. To tighten, turning the clamp in a clockwise direction.

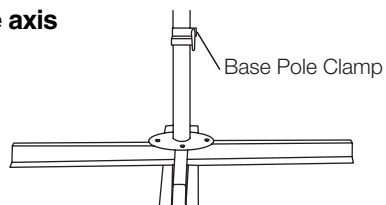

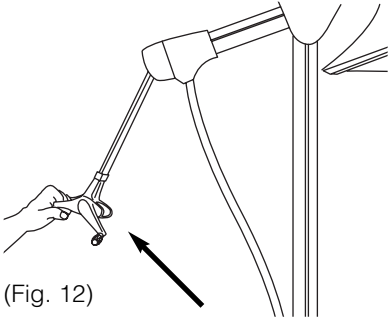

(Fig. 12)

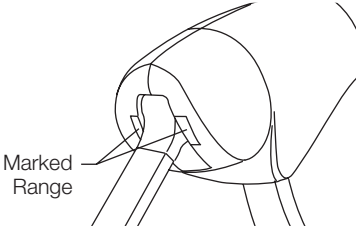

(Fig. 13)

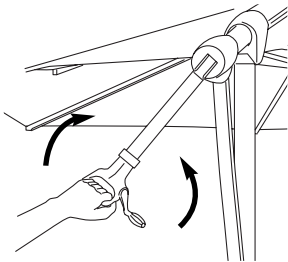

(Fig. 14)

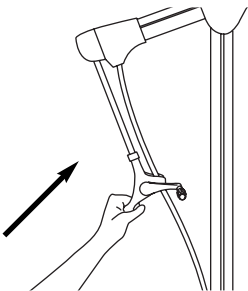

(Fig. 15)

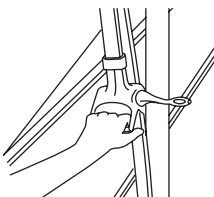

(Fig. 16)

To ADJUST the TILT

1. Pull the operating handle to release the crank case and steering rod from the support strut (Fig. 12).
2. Pull the steering rod further away from the support strut (to an angle of about 45°) until the steering rod is in the **marked range** (Fig. 13). This releases the tilt gear.
3. While still in the marked range, rotate the steering rod to the left or right, to the angle you wish to tilt (but opposite the direction of your desired tilt). *i.e.:* If you wish to rotate the canopy 15° clockwise, then rotate the steering rod 15° counter-clockwise. NOTE: The canopy will not tilt during this motion.
4. Re-engage the tilt gear by pushing forward slightly (out of the marked range).
5. While still engaged, pull (rotate) the steering rod back to the center position. The canopy will now rotate with the direction of the steering rod.
6. Push the steering rod straight forward until the operating handle locks into place on the support strut. Your canopy should now be locked into its tilted position.
7. To return canopy to its horizontal position (which **MUST** be done before closing the umbrella) simply do these steps in reverse. Start by pulling the operating handle slightly away from the support strut, but **NOT** into the marked range. Rotate the canopy back to horizontal, then pull the steering rod into the marked (release) range; which will allow the steering rod to move freely back to the center position.

VEGA™ LIGHT ADAPTER :

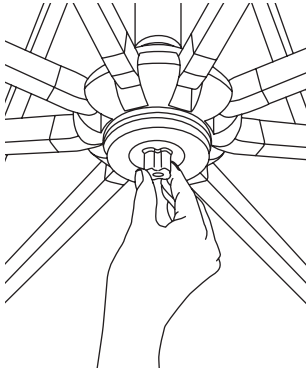

(Fig. 17)

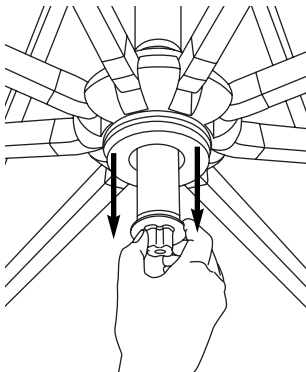

(Fig. 18)

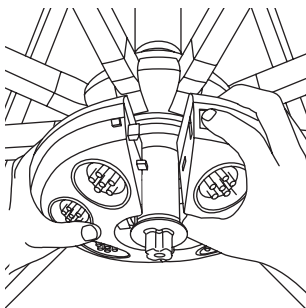

(Fig. 19)

To ATTACH VEGA Umbrella Light:

1. Loosen the VEGA light adapter built into the umbrella runner by turning counter-clockwise (Fig. 17). 
2. After loosening, pull down light adapter post (Fig. 18) to attach the VEGA umbrella light (sold separately).

To OPEN and ATTACH VEGA:

1. Open the VEGA umbrella light by holding firmly with one hand and then depress the clamp release button with the other hand to release the clamp lock.
2. Open up the VEGA light and clasp around the light adapter post (Fig. 19).
3. Snap to close (Fig. 20).

To REMOVE VEGA and CLOSE adapter:

1. Hold the VEGA umbrella light, depress the clamp release button to release the clamp lock.
2. Remove VEGA umbrella light, and gently push up the light adapter post back into umbrella runner and tighten turning clockwise (Fig. 17). 

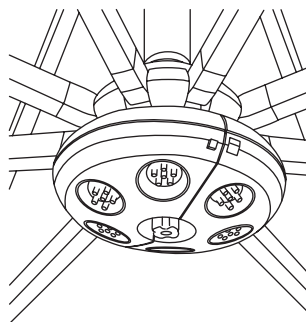

(Fig. 20)

WARRANTY:

Treasure Garden warrants this product (in residential use) to be free from defects in original materials and workmanship for a period of 1 year from the date of purchase.

If a defect in the original material or workmanship appears during the warranty period; Treasure Garden will (at its option) repair or replace the product without charge.

Simply contact your original authorized Treasure Garden dealer with a description of the defect. The dealer will verify the defect and work closely with Treasure Garden to obtain the necessary service.

In many cases, simple problems can be solved with a replacement part that can be shipped directly to the dealer for professional installation / repair.

In the event that warranted factory service is required, Treasure Garden will assume the responsibility of the return freight charges on warranted product for the first year only.

Returned product that (upon receipt and inspection) is deemed to be "not covered" under our warranty, will be shipped / billed at your expense.

This warranty gives you specific legal rights, and you may have other rights which vary from state to state.

NOTE: Failure caused by unreasonable or abusive use, or failure caused by neglect of reasonable and necessary care are not covered by this warranty.

Additionally, acts of nature (including but not limited to wind, hurricanes, tornadoes, and storms) are not covered by this warranty.

S A F E T Y P R E C A U T I O N S :

- Close the umbrella in windy conditions or when a storm approaches. Never allow the umbrella to flap in the wind; this could damage the canopy.
- Do not leave open umbrella unattended. If damage occurs, this is not covered by the warranty.
- When adjusting the umbrella, make sure that no person(s) or item(s) are close to the umbrella. This is important to prevent injury or material damage.

C A R E A N D M A I N T E N A N C E :

- When not in use, close and cover umbrella with a protective cover (sold separately).
- Allow a wet canopy to dry opened up.
- If necessary, clean the fabric with lukewarm water, mild detergent, and a sponge.
- Wipe sliding marks on the aluminum poles with a damp cloth.

Winter Storage:

- Store in a dry place.
- Any visible defects must be repaired by a professional.

After the Winter:

- Areas subject to turning and sliding can be treated with a non-staining lubricant spray (silicone-based).
- Check the condition and function of the umbrella. Any defects must be repaired by a professional.



www.treasuregarden.com